

mahindra
TRUCK AND BUS

**FUELING THE ECONOMY
WITH IOT IN ENERGY
DISTRIBUTION.**



FURIO_{1.0}
6 KL FUEL BOWSER



*Chassis is approved for POL application in accordance with Rule 70 (i)(ii)&(iii) of The Petroleum Rules, 2002

IT'S GOT EVERYTHING THE PERFECT DIESEL BOWSER NEEDS.

The Mahindra **FURIO** makes the perfect diesel bowser with its build, performance, driving comfort and safety. While its build makes it more profitable, it has several features that add to productivity.

BUILT FOR BIG PROFITS.



More Load Carrying Capacity:

Brings you more earnings



Assured Higher Mileage with FuelSmart Technology:

Increases your profitability



iMAXX Intelligent Telematics Technology:

Keeps track of your truck from anywhere and, makes transporting more efficient and profitable



Superior Driving and Cabin Comfort:

Makes drivers more productive



Smart Fuel Sensors

Real-time data on accurate diesel levels, ensuring timely refills for Repos Fuel Stations.



Intelligent Geo-Fencing

Secure diesel dispensing within the order radius, preventing unauthorized use.



Timely Diesel Reports

Receive weekly, monthly, and daily diesel dispensing reports through the Repos app.



Timely Diesel Reports

Receive weekly, monthly, and daily diesel dispensing reports through the Repos app.



BUILT FOR PERFORMANCE



Strong and Rugged Aggregates:
Gives you greater vehicle reliability



Lower Turning Circle Diameter:
For effortless city driving Conditions

FURIO 10 Chassis	7T @ 5334 mm
5334 mm Straight Ladder and High Strength Low Alloy 550 Material Chassis with Reinforcements	

MAHINDRA FURIO 10 -5334 mm CBC LAYOUT

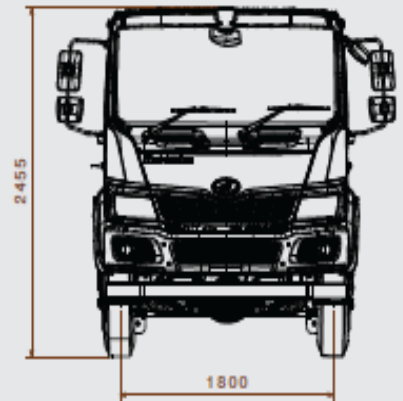
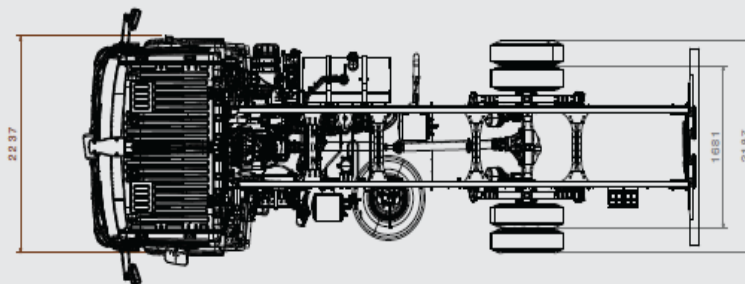
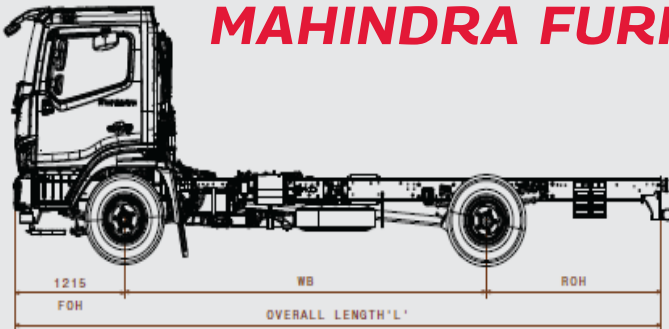

*Refer Body Building, PTO, ABS, Protective Shield Guidelines, Dos & Don'ts

Note :

- ARAI reports are available for Heat shield and Spark arrestor
- As per ARAI report , Spark arrestor is not required
- Vehicle should meet statutory licenses as per MV act and PESO act (if applicable).

MODEL TECHNICAL SPECIFICATIONS & FEATURES - FUEL BOWSER

Features		FURIO	Comp. 1	Comp. 2
Engine	Hydraulic Lash Adjuster	√	x	x
	Auto Belt Tensioner	√	x	x
Safety	Cab - Energy Absorbing Mounts	√	x	x
	Wide Spread Fog Lamps	√	x	x
	Neutral Safety Start Switch	√	x	x
	Wire Mesh @ Fuel Tank Neck	√	x	x
Comfort	Lounging Arrangement	√	x	x
	(Co Driver Side)			
	Air Outlets - Ventilation	8# Vents	4# Vents	4# Vents
	5 Deg. Cooler Cab	√	x	x
	(Lower Rake Angle Design)			
	Centre Seat cum Storage	√	x	x
	Day Cab			
Convenience	Roof Luggage Carrier / Aero Kit	√	x	x
	Mounting Provision			

Diesel Bowser Capacity	6KL
Wheelbase (mm)	4000
GVW (kgs)	10350
Engine	mDi Tech, 4 Cylinder BSVI OBD2 3.5L Engine with Fuelsmart Switch - 2 modes: Empty & Load
Power	Power: 91.5KW @ 2500 rpm
Torque	375 Nm 1300 - 2000 rpm
Transmission	MNT 55 with Neutral Start Switch 6F + 1R, Cable Shift
Clutch	Single Plate Dry Push Type with Clutch Booster Dia. 330 mm, B8090 LUK Liner
Gradeability	29.40%
Chassis	HSLA 550 Material 210 x 65 x 5 mm
Suspension	Front: Parabolic Leaf spring Rear: Semi elliptic leaf spring
Steering	Hydraulic power assisted, Tilt & Telescopic (430 mm)
Ground Clearance (mm)	220
Fuel Tank (Lit)	185L - Plastic tank
Ad Blue Tank (lit)	13L
Brakes	Air Brakes Drum (325 x 140)
Tyre Size	8.25R16 - 16PR - STD Radial Tyres
Cabin	2.05m Day Cabin
Deck Length (Ft)	17.5
TCD (m)	14.9



PROVEN MDI TECH ENGINE **GREATER EFFICIENCY AND PERFORMANCE**

- *Hydrolic Lash Adjuster - No Manual Tappet setting required*
- *Automatic Belt Tensioner for hassle free maintenance*

PROVEN GEAR BOX

- *MNT 55 6S, Neutral Start Switch*
- *Higher torque of 375 Nm*
- *Lesser Gear Shifts*



ROBUST AGGREGATES

- *HSLA 550 Chassis - Greater stability*
- *Strong and durable rear axle*

BEST-IN-CLASS MILEAGE **WITH FUELSMART** **TECHNOLOGY**



STANDARD **RADIAL TYRES** *For enhanced tyre life*

BEST-IN-CLASS SAFETY

- *Widespread Fog Lamps for Excellent Night Visibility*
- *8 Bar Brake System - Better control on Road*
- *Safest Cabin - Best in Class Survival Space*
- *Neutral Safety Start Switch*
- *Roof Luggage Carrier/ Aero Kit - Mounting Provision*
- *185 L Plastic Fuel Tank*
- *Wire Mesh at Fuel Tank Neck*



HAPPIER DRIVERS MAKE FOR MORE PRODUCTIVE DRIVERS.

The Mahindra **FURIO** makes driving more comfortable. This allows drivers to make more trips which in turn contributes significantly to your earnings. In fact the driver's comfort was an overlooked factor for many years. But Mahindra **FURIO** has changed that completely.

- Space enough for two drivers
- Roomy cabin, with lower noise and vibration
- Ample resting space in cabin during stopovers; means less tiredness over long drives
- Well-ventilated cabin brings down temperatures; especially in hot conditions
- Gives you market rate business edge by making on-time delivery possible
- Cabin provides higher operational comfort
- Comfort that makes night-driving less of an effort
- Good cabin ergonomics leading to higher trip efficiency



*Sleeper Berth is the optional fitment in FURIO 10
To know more, visit www.mahindratruckandbus.com.

WITH MORE SAFETY COMES MORE ASSURANCE.

The Mahindra **FURIO** has several safety features to not only make drivers feel safer at higher average driving speeds but also give you the assurance of cargo safety. This is another reason why this truck is ideal for drivers and an important addition to your fleet, especially for perishable goods.



Widespread Fog Lamps for Excellent Visibility at Night and in Dark Conditions



Front Anti-Roll Bar for Greater Stability on the Road (Optional)

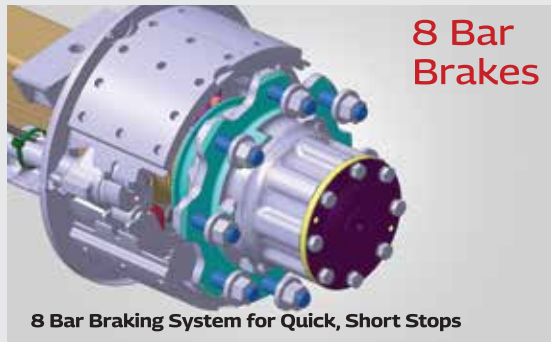

8 Bar Brakes

8 Bar Braking System for Quick, Short Stops

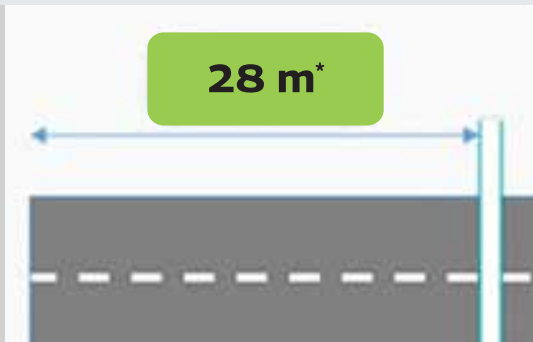

High Strength Low Alloy Chassis for Higher Strength and a Greater Sense of Security



Tubeless and Radial Tyres* for High Speed Capacity, Better Stability And Puncture Resistance



Safest Cabin with Best-in-Class Survival Space

MONITOR YOUR TRUCK EVERY SINGLE MOMENT.

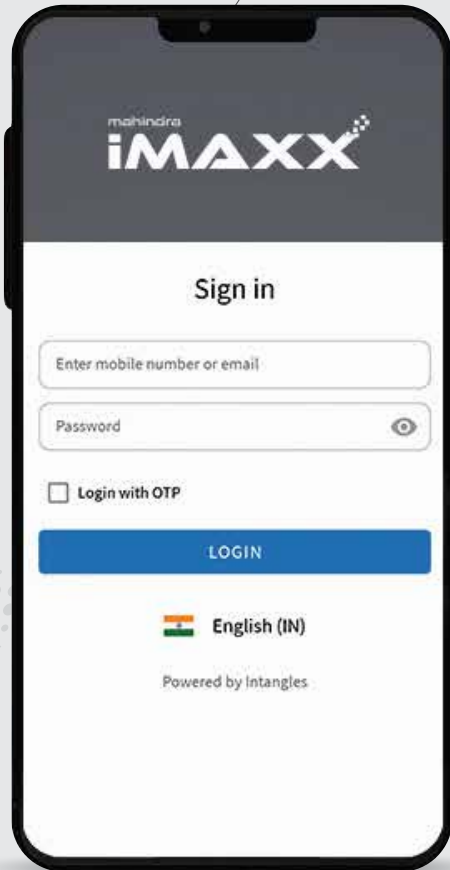

VEHICLE HEALTH MONITORING



Fault Codes (DTC) and Repair Strategies



Battery and Alternator



Engine Temperature Check



Turbocharger and Intercooler

FUEL AND ADBLUE ANALYSIS



Fuel Economy Analysis



Fuel Filling and Theft Monitoring



AdBlue AUS32 Monitoring



FuelSmart Switches Usage Analysis

DRIVING BEHAVIOUR MONITORING



Neutral Driving and Gear Utilisation



Idling



Hard Braking and Harsh Acceleration



Overspeeding

OPERATIONS AUTOMATION



Hub Reports



Vehicle Utilisation Reports



Vehicle Live Data



Location Track and Trace



Get Timely Service Reminders



MAHINDRA AASHRAY MAKES EVERY MOMENT CAREFREE.



Mahindra MCOVER Makes You Feel 3 Times More Secure.



Mahindra brings you MTRUST, the best way to buy used Mahindra trucks. We put each vehicle through 166 tough health checks. Refurbish with only Mahindra spares. All to give you trucks that are as good as new and outperform right from the start.

• UP TO 12 MONTHS WARRANTY • 1/2/3 STAR RATINGS • UP TO 3 FREE SERVICES • ROADSIDE ASSISTANCE • REFINANCE OPTIONS



Corporate: contactmtb@mahindra.com
Customer Care: now24x7@mahindra.com



www.mahindratruckandbus.com



Mahindra and Mahindra Ltd.
Truck and Bus Division, Marketing Division, Mahindra Tower,
5th Floor, Wing 4, Chakan Industrial Area, Phase IV,
Post - Nighoje, Chakan Tal Khed, District Pune - 410 501

Note: In view of our policy of continuously improving our products, we reserve the right to alter specifications or design without prior notice and without liability. Illustrations do not necessarily show the vehicle in its standard form. Accessories shown are not part of the standard equipment. Colour shades shown may vary. E. & O.E.

DEALER STAMP



To know more, give us a missed call on:
1800 315 7799
Visit www.mahindratruckandbus.com

 **MOBILE SERVICE VANS & WORKSHOPS**

 **COUNTRY-WIDE SPARES & SERVICE NETWORK**

 **WHATSAPP US ON: 8484970171**

 **1800-200-3600**
24/7 VEHICLE ASSISTANCE BY EXPERTS
A MULTILINGUAL SERVICE