

SWITCH NOW AND WATCH YOUR BUSINESS GROW.

GET USED TO GETTING MORE.



Fruits and Vegetables



E-commerce and Parcel

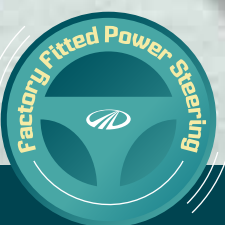

MAHINDRA, INDIA'S
MOST FUEL-EFFICIENT
TRUCK RANGE.
GUARANTEED.

Presenting the all-new



Mahindra

JAYO



1800 315 7799

visit www.mahindratruckandbus.com

*For more details of this guarantee, visit www.mahindratruckandbus.com

Mahindra
JAYO BS6

The Mahindra JAYO BS6 contributes to business growth in a big way. It has the Highest Payload, Highest Mileage and the Highest Loading Span. It's perfect for more than 35 applications. And it gives you peace of mind with its unbeatable service and spares guarantees. Even your driver will love this truck. For its comfort and the many safety features. Read on and see why the all-new Mahindra JAYO BS6 is the best bet for your business.



FRUITS AND VEGETABLES

MARKET LOAD

CONSUMER DURABLES

FMCG

PARCEL AND COURIER

FUEL DISPENSER

REEFER

E-COMMERCE

Mahindra
JAYO BS6

SWITCH NOW AND TASTE **SUCCESS** LIKE NEVER BEFORE.

NOW, MAKE TWICE THE OPERATING PROFIT.*

The Mahindra JAYO BS6 is the perfect LCV for delivering fruits and vegetables. Designed to drive through even small and narrow lanes, it's just the truck you want for typical Indian market conditions. See what makes the Mahindra JAYO BS6 the most profitable choice for delivering fruits and vegetables.



Higher mileage



2.6T High Side Deck (HSD) gives you greater load carrying capacity



Shortest overall length for last mile delivery



Compact and easy to manoeuvre even in narrow lanes



Smaller Turning Circle Diameter (TCD)



Best fit load body



THREE TRUCKS WILL BUY YOU A FOURTH TRUCK IN THREE YEARS*

- More comfort makes drivers make more trips
- Ready to transport from the very first day



High Strength Material steel gives you a durable body and a payload advantage



Internal dimensions –
Length x Width x Height:
(3220 X 1920 X 1350) mm



Crash guard in DSD bodies -
Makes the cabin safer for the driver

The Mahindra JAYO packs in so many profit-making advantages that when you buy three of these trucks, the Return on Investment will pay for a fourth Mahindra JAYO BS6 ... in other words the fourth truck will be free!

- ▶ Best-in-class mileage and higher payload carrying capacity
- ▶ More comfort leads to happy drivers and more trips
- ▶ Ready-to-use load body from day one

BODY DIMENSIONS SUITABLE FOR CRATES AND SACKS

Mahindra JAYO BS6 gives you an operating profit of Rs. 2.7 Lakh in 3 YEARS*

Competition	Mahindra JAYO	Mahindra JAYO Advantage
210 Nos*	245 Nos*	35 Crates ↑
2591 mm	3220 mm	629 mm LB ↑



*To know more, visit www.mahindratruckandbus.com

SWITCH NOW AND EXPERIENCE **PROSPERITY** BY THE PARCELS.

NOW, MAKE THRICE THE OPERATING PROFIT.*

The Mahindra JAYO BS6 is ideal for delivering any shape or weight of e-commerce parcels. Easy to manoeuvre on any road, it is especially good for accessing any customer location, even small, narrow lanes. See what makes this truck such a profitable e-commerce partner.



Higher payload of 2.6T (HSD)



High volumetric capacity with internal dimensions of 3076 x 1790 x 1960 (mm)*



Smaller Turning Circle Diameter (TCD) of 11.5 m



Power steering for effortless driving



Mild Steel container body for strength and long-time durability



*To know more, visit www.mahindratruckandbus.com
*T&C apply for availability of fully-built model

HIGHER VOLUMETRIC PAYLOAD

MULTIPLE CHASSIS LENGTH VARIANTS TO MULTIPLY YOUR PAYLOAD

- Strong chassis for a container
- Lower chassis weight gives you higher volumetric payload
- Longer chassis length perfect for large cargo

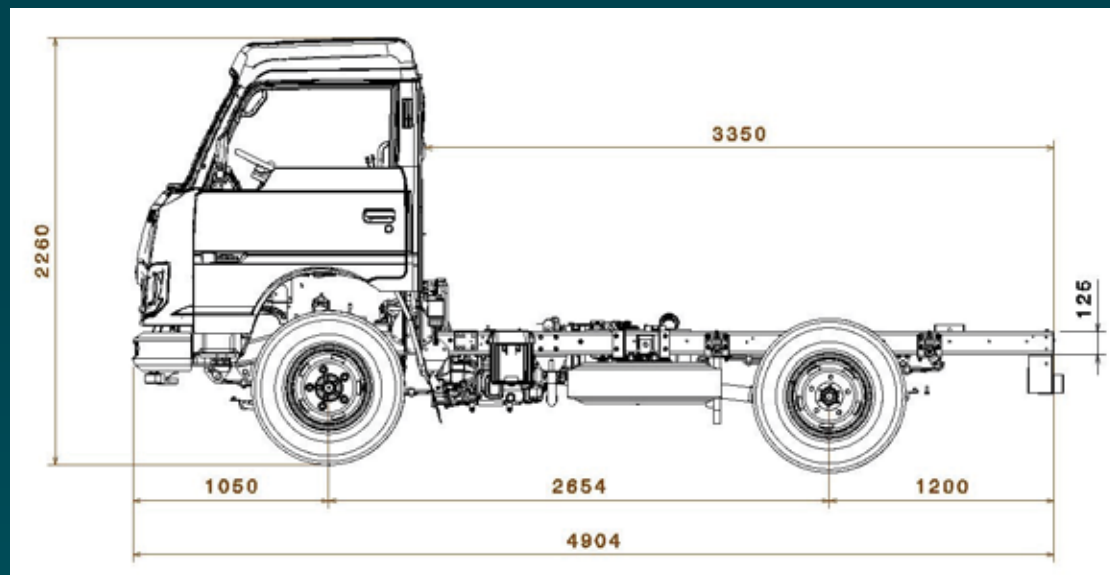
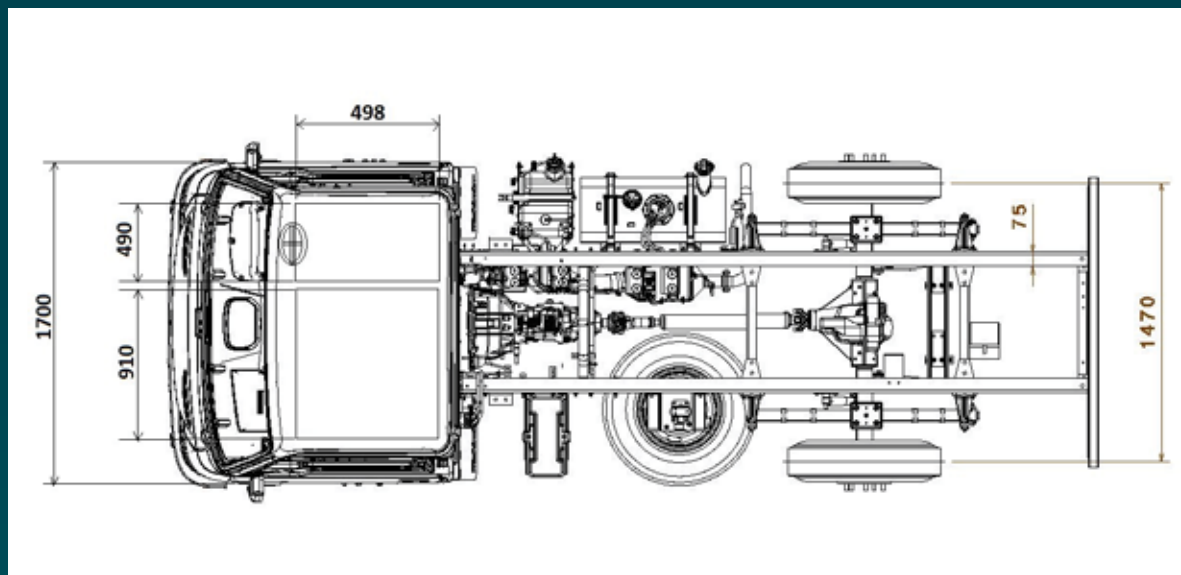

Easy to modify as per your need

MAHINDRA JAYO GIVES YOU A PAYLOAD ADVANTAGE WHETHER YOU -

- ▶ Transform a Cargo Body model into a Container Truck
- ▶ Build a Container Truck from a Cabin-Chassis model

Product	Payload
Mahindra JAYO BS6 MS Container**	2.4T*

Mahindra JAYO BS6 MS CONTAINER	
CONTAINER	
L x W x H	(3076 X 1790 X 1960) mm*
Internal Dimensions (mm)*	



*Container
**Recommended Container Size

*To know more, visit www.mahindratruckandbus.com
*T&C apply for availability of fully-built model

BIG COMFORT LEADS TO BIGGER PROFITS

Driving the Mahindra JAYO can be so much more comfortable. What with all the thoughtful features built into it. In fact driving comfort is one of this truck's biggest strengths and plays a big role in making your drivers more productive.

- 4-way adjustable (Sliding FR, RR and Recliner FR, RR) driver seat for individualised comfort
- Well-ventilated cabin brings down summer heat and lowers overall cabin temperature
- Good cabin ergonomics provide higher operational comfort
- Extra comfort leads to on-time deliveries, a key requirement for market rate advantage

EVERY FEATURE IS ENGINEERED TO GROW YOUR BUSINESS



HIGHEST MILEAGE

- Trusted mDi engine
- Proven Bosch ATS system for Lower AdBlue consumption



EXTRA CONVENIENCE



Bottle holder



HIGHEST PAYLOAD

- Highest body length of 3220 mm
- Loads more, earns you more profits



Mobile charging point



ENHANCED COMFORT



4-way Adjustable driver seat (Sliding FR, RR and Recliner FR, RR)



Ergonomic Dashboard for easy access



Dual Toned Fabric seat



ADDED SAFETY



Larger Windows for Increased inflow of air



Clear Lens Headlamps for Higher light output



Blower to Improve air circulation



Metallic Bumper for Impact resistance

ENGINEERED FOR EXTRA ECONOMY

HIGHER PAYLOAD AND HIGHEST MILEAGE MEANS HIGHER PROFITS

- Proven mDi Engine (BOLERO Engine)
- 12+ YEARS of CRDe expertise
- Aerodynamic Design and optimised driveline ratio
- Low AdBlue consumption

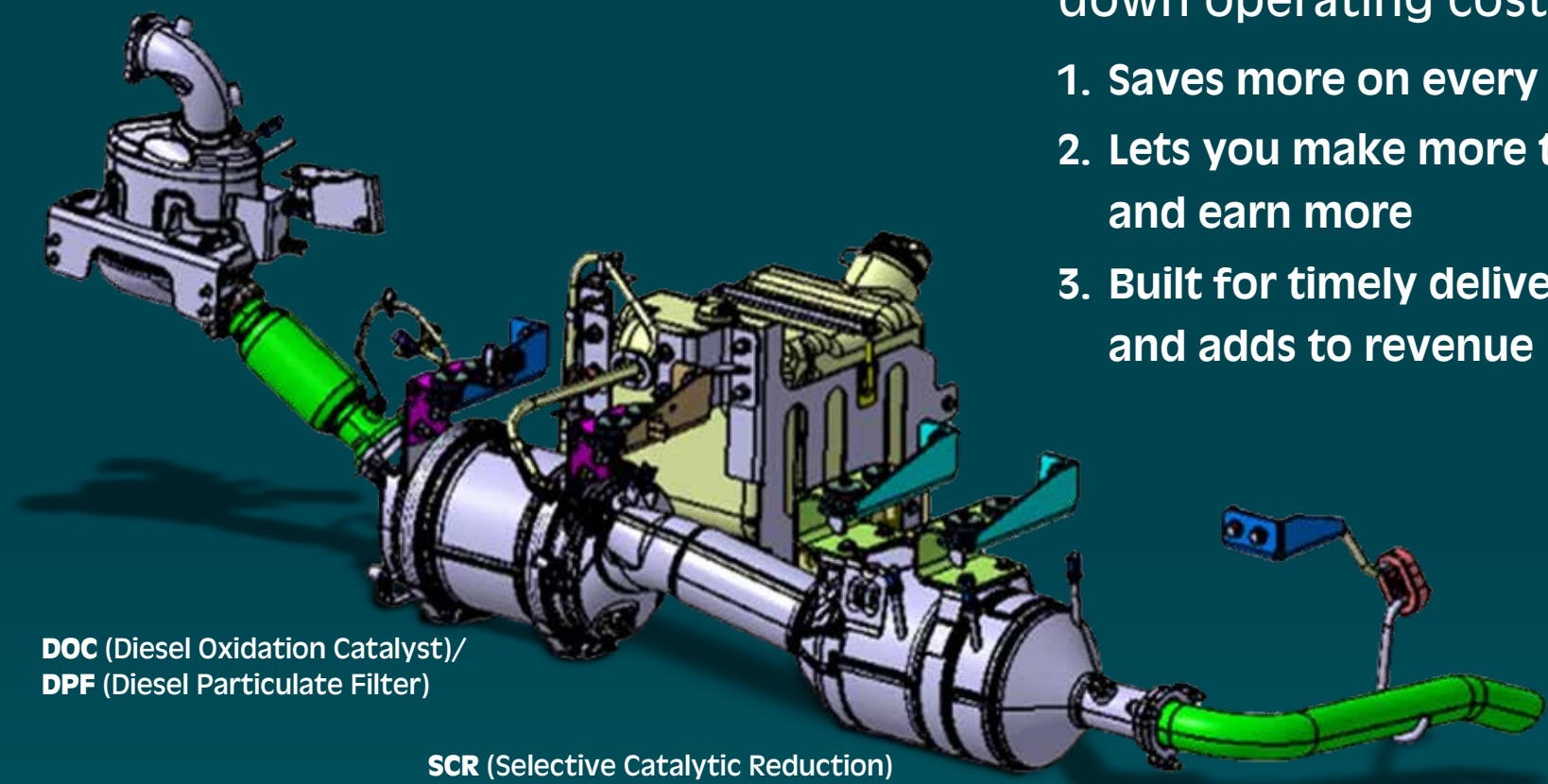

DOC (Diesel Oxidation Catalyst)/
DPF (Diesel Particulate Filter)

SCR (Selective Catalytic Reduction)

- Higher mileage brings down operating costs
 1. Saves more on every trip
 2. Lets you make more trips and earn more
 3. Built for timely delivery and adds to revenue

Proven Bosch ATS System

RELIABILITY AND PROFITABILITY

- Higher load carrying capacity
- Greater reliability makes it ideal for perishable goods
- Minimal impact on payload as changes from BS4 to BS6 are minimal
- 90% BS6 parts common with BS4
- Same chassis and load body
- 2.6T Payload in 3220 mm HSD load body

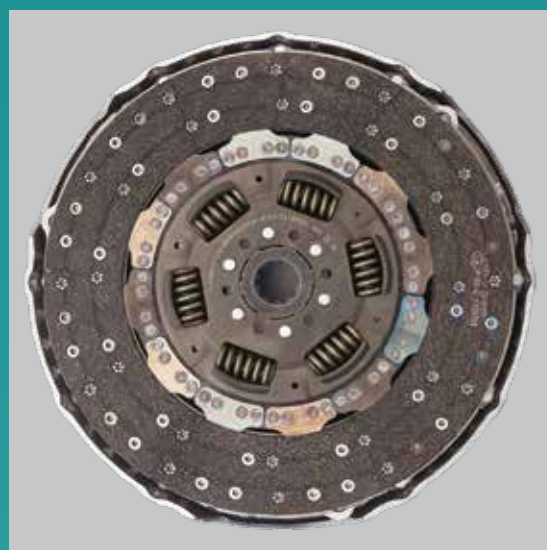

Clutch



Anti Roll Bar



Rear Axle



Chassis Frame
(High Strength Material 420)





Think of the Mahindra iMAXX telematics technology as your personal assistant that updates you with vital information about your vehicles and business. Mahindra iMAXX comes with smart features like Accurate Refills, Live Tracking, Predictive Vehicle Health Monitoring, Fuel Efficiency Analysis, Theft Alerts, Fuel Consumption, Adblue Monitoring, Driver Behaviour Monitoring and a range of Automated Operation Reports. With the help of these features, owners can keep track of their vehicles and business 24/7.*

KEY FEATURES



PERSONALISATION

As your business evolves, so does our technology to suit all your needs.



ZERO DATA LOSS

It's equipped with a bigger battery and memory to store data. In addition, it also works on all generations - 4G, 3G and even 2G.



100% RELIABILITY

Backed by artificial intelligence so you get accurate results every day.



SMART REPORTS

Gives analytical insights and reports regularly to monitor and grow your business.



Mahindra AASHRAY is an insurance policy for truck and bus drivers that comes free with every Mahindra truck or bus. It provides financial support up to Rs. 5 Lakh in case of loss of limb or life. To take care of hospitalisation expenses, family support and if needed, even children's education expenses. It's our way of showing how deeply we care about the welfare of drivers. It's our way of making every Mahindra truck or bus even more complete.



MCOVER

Mahindra MCOVER Makes You Feel 3 Times More Secure.

- ① Cashless and Zero Depreciation Settlement*
- ② New vehicle replacement in case of total loss*
- ③ Compensation for loss of income*



Pre-owned Commercial Vehicles

Mahindra brings you MTRUST, the best way to buy and sell used Mahindra trucks and buses. We inspect each vehicle from bumper to bumper through 166 check points at our authorised dealerships and make put them through 36 tough health checks as well. If there are any worn-out/non-working parts, we refurbish them with genuine Mahindra spares to give you vehicles that are as good as new and outperform from the word go.*



SERVICE AND SPARES GUARANTEES

- GET BACK ON THE ROAD IN **48 HOURS** OR GET ₹1 000.00 PER DAY.*
- GET A **36-HOUR** GUARANTEED TURNAROUND AT OUR WORKSHOPS OR GET ₹3 000.00 PER DAY
- GET THE **HIGHEST MILEAGE** OR GIVE THE TRUCK BACK

TECHNICAL SPECIFICATIONS.

Model		Mahindra JAYO BS6
Weights	GVW (kg)	4990
	*Payload HSD (kg)	2610
	Tyres	7.0 x 16
Cabin	Cabin Width, Type	1.7 m Narrow Day Cab
	Tilt Cab	Fixed Cab
Dimension	Wheel Base (mm)	2654
Load Body	Cargo Length	3220 mm
	Cargo Width	1920 mm
	Panel Material	D Grade
Driveline + ATS	Engine	mDi
	Model	2.5 litre, 4 Cylinder
	Power	60.5 kW @ 3200 r/min
	Torque	220 Nm @ 1250-2200 r/min
	ATS Technology	EGR + SCR
	Transmission	BD 30 : 5S
		Cable Shift - GSL
Clutch (Diameter)	260 mm	

Model		Mahindra JAYO BS6
Frame	Section	120 x 75 x 5 (mm)
	Material	HSM 420
Suspension	Springs Type	Front & Rear - Semi Elliptical
Brakes	Type	Hydraulic Brakes (Drum)
Fuel Tank	Capacity & Material	60 litre - Metal
Ad Blue Tank	Capacity	13 litre
Performance	TCD	11.5 m
	Gradeability	30%
Service Intervals	Service Interval	10.000, 35.000 km
	Warranty*	3 YEARS / 3 Lakh km*

*To know more, visit www.mahindratruckandbus.com



Available in 3 different colours

Marino Blue

Rose Red

Pearl White



- 3 YEARS/ 3 Lakh km Warranty*
- Transferable Warranty*

*1st Year Standard Warranty and 2nd and, 3rd Year Warranty On Driveline Only

To know more about Mahindra Truck and Bus give us a missed call on



1800 315 7799

